Lokální síť (04)

Jan Janeček

katedra počítačů

České vysoké učení technické v Praze

Ethernet technologies

- Standard (10BASE-x) technologies
 - 10BASE-5, 10BASE-2
 - 10BASE-T, 10BASE-FL, 10BASE-FB, 10BASE-FP
- Fast (100BASE-x) technologies
 - 100BASE-Tx/Fx
 - 100BASE-T4, 100BASE-T2
- Gigabit (1000BASE-x) technologies
 - 1000BASE-SX, 1000BASE-LX
 - 1000BASE-CX, 1000BASE-TX

IEEE 802.3 Architecture

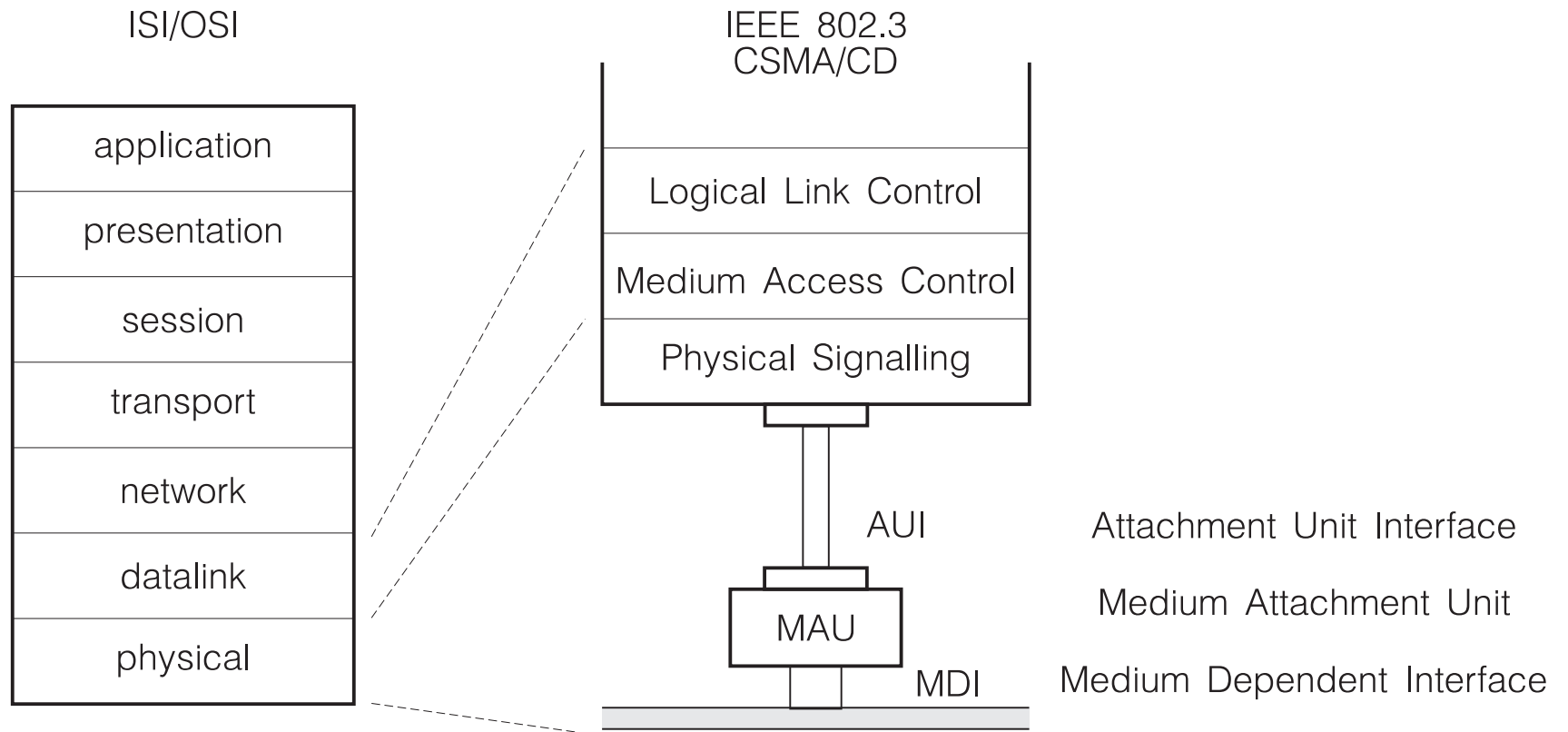

IEEE 802.3 10BASE-5

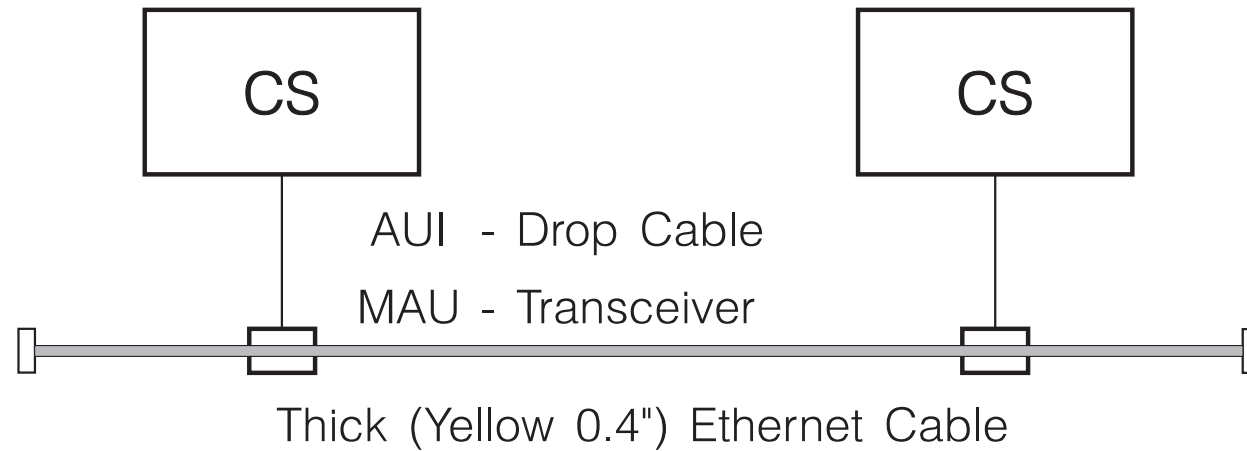

IEEE 802.3 10BASE-5 FOIRL

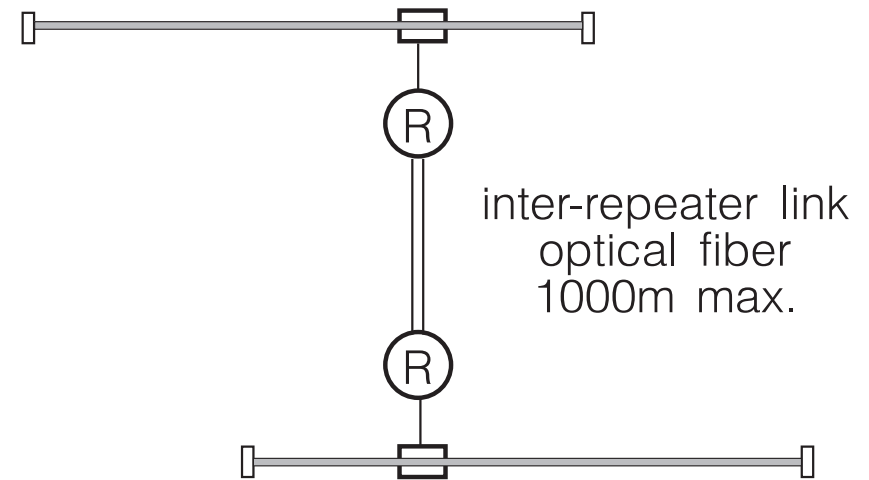
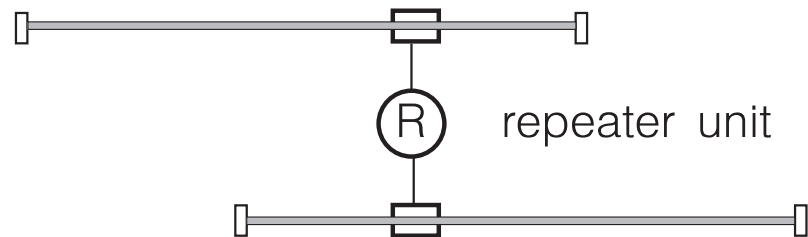

Ethernet formats / access control

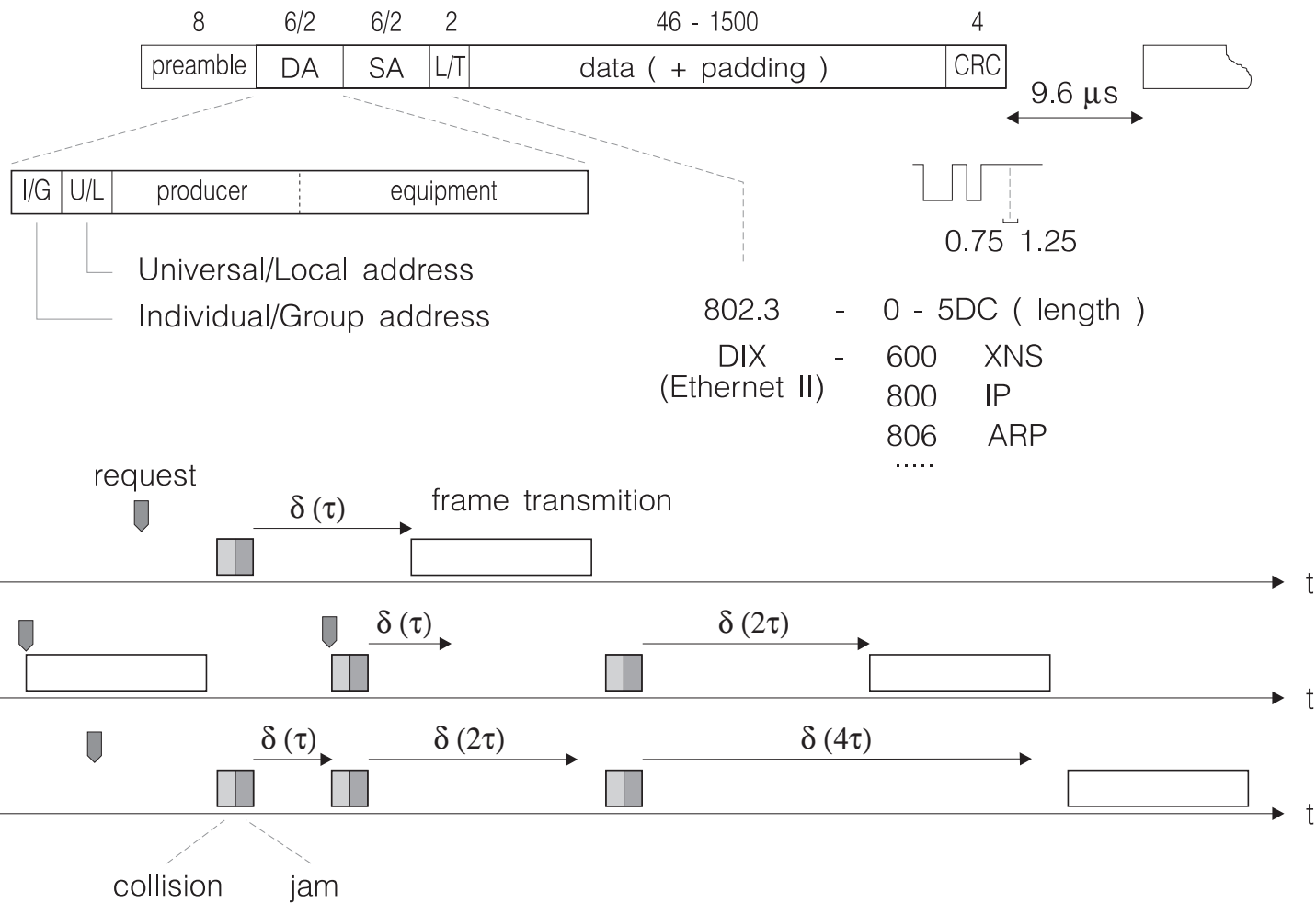

IEEE 802.3 10BASE-2



IEEE 802.3 10BASE-2 Cabling

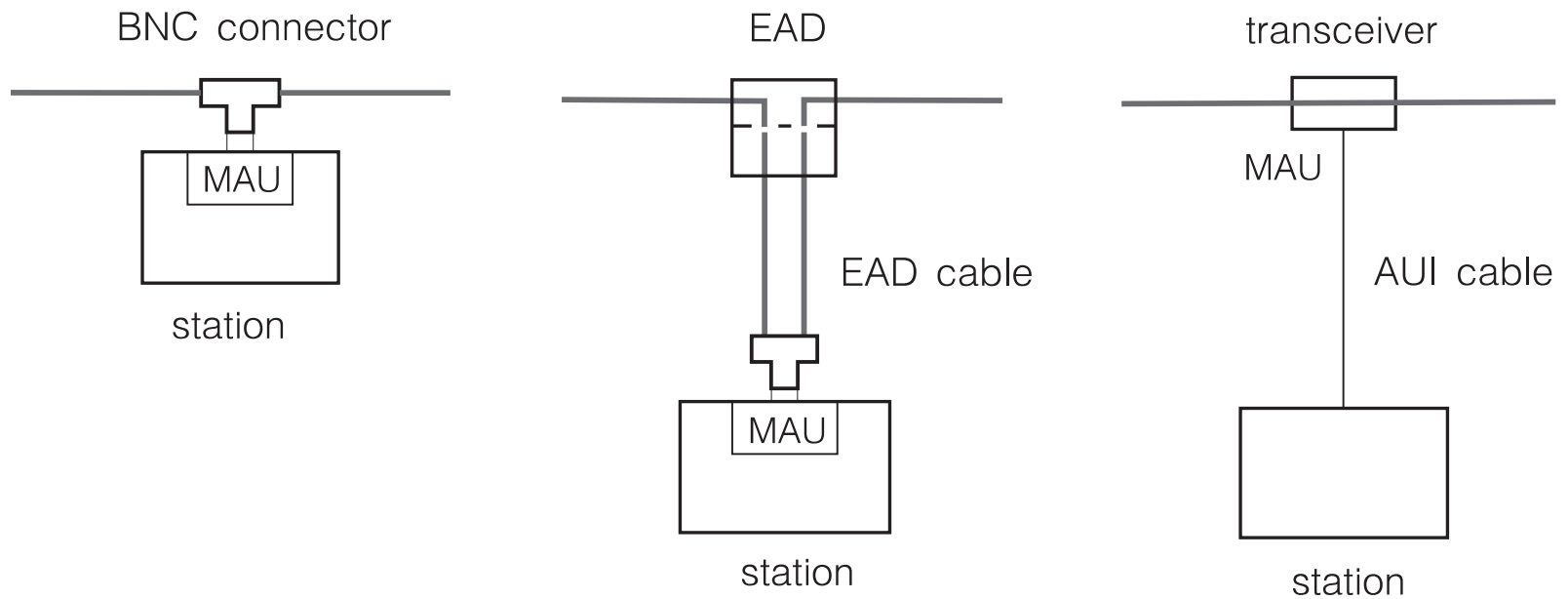

IEEE 802.3 10BROAD-36

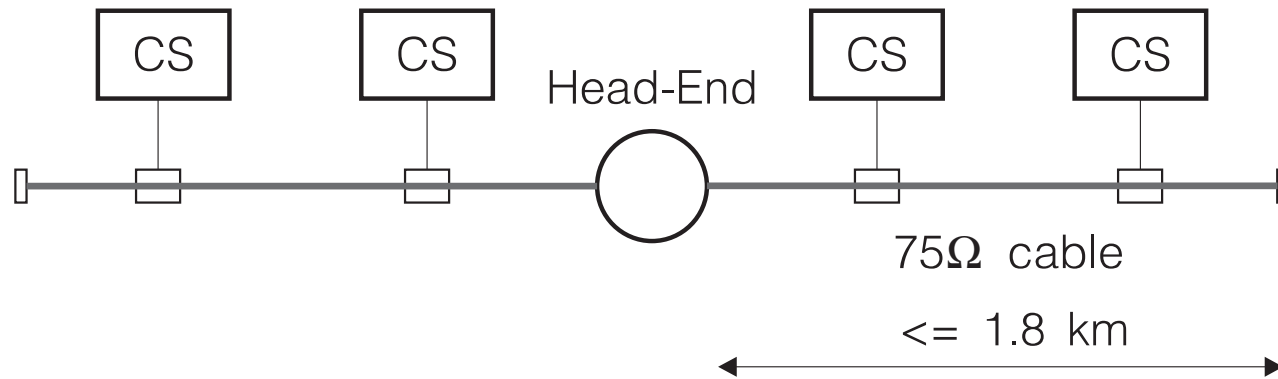

IEEE 802.3 1BASE-5

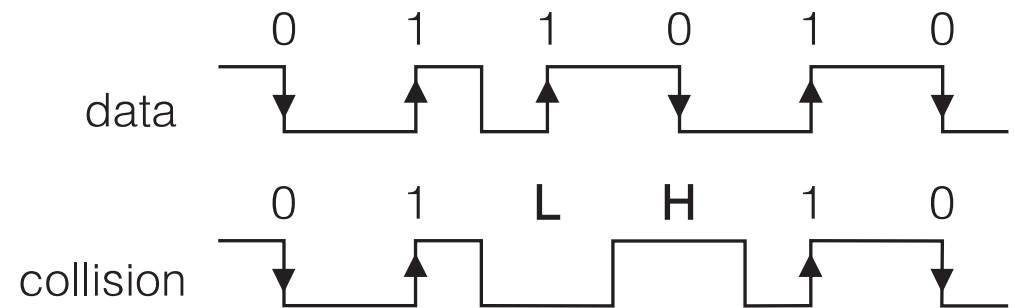
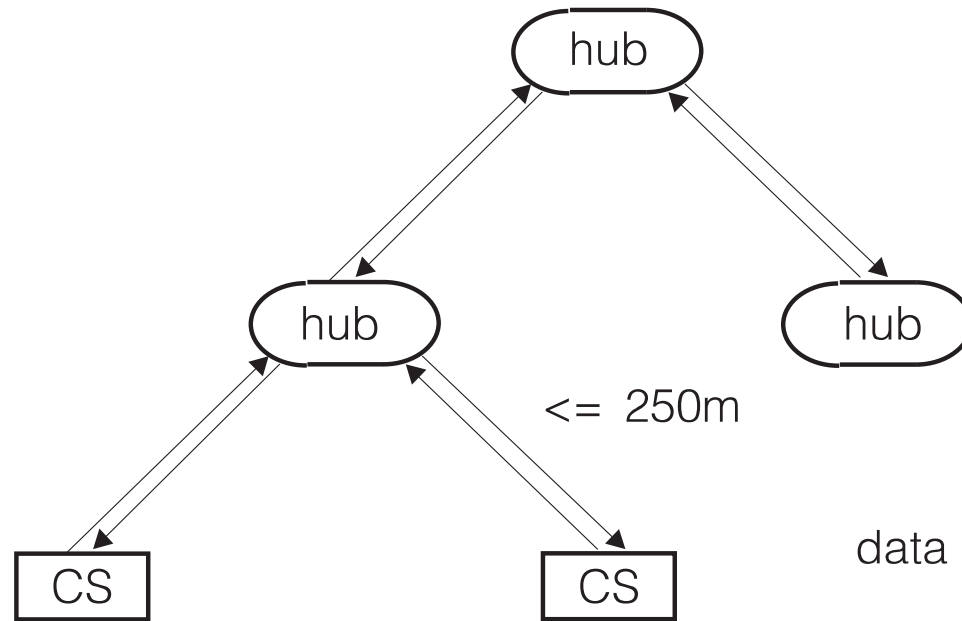

IEEE 802.3 10BASE-T

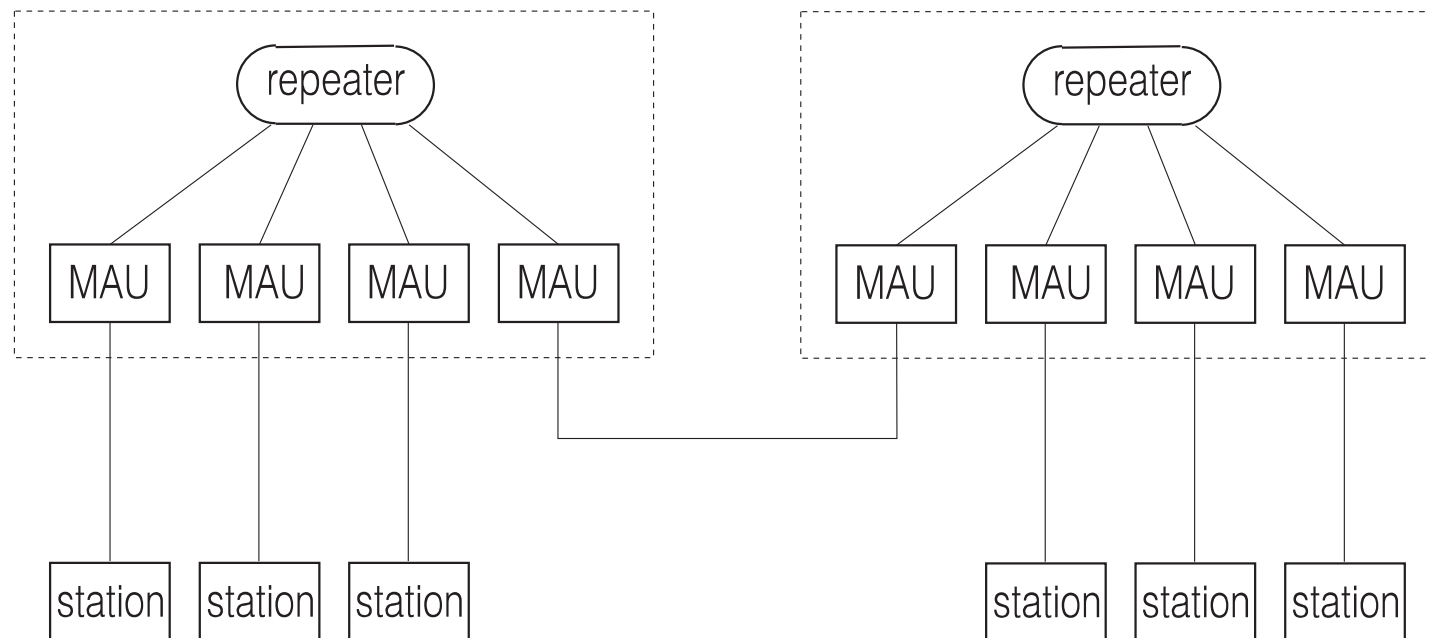

IEEE 802.3 Ethernet

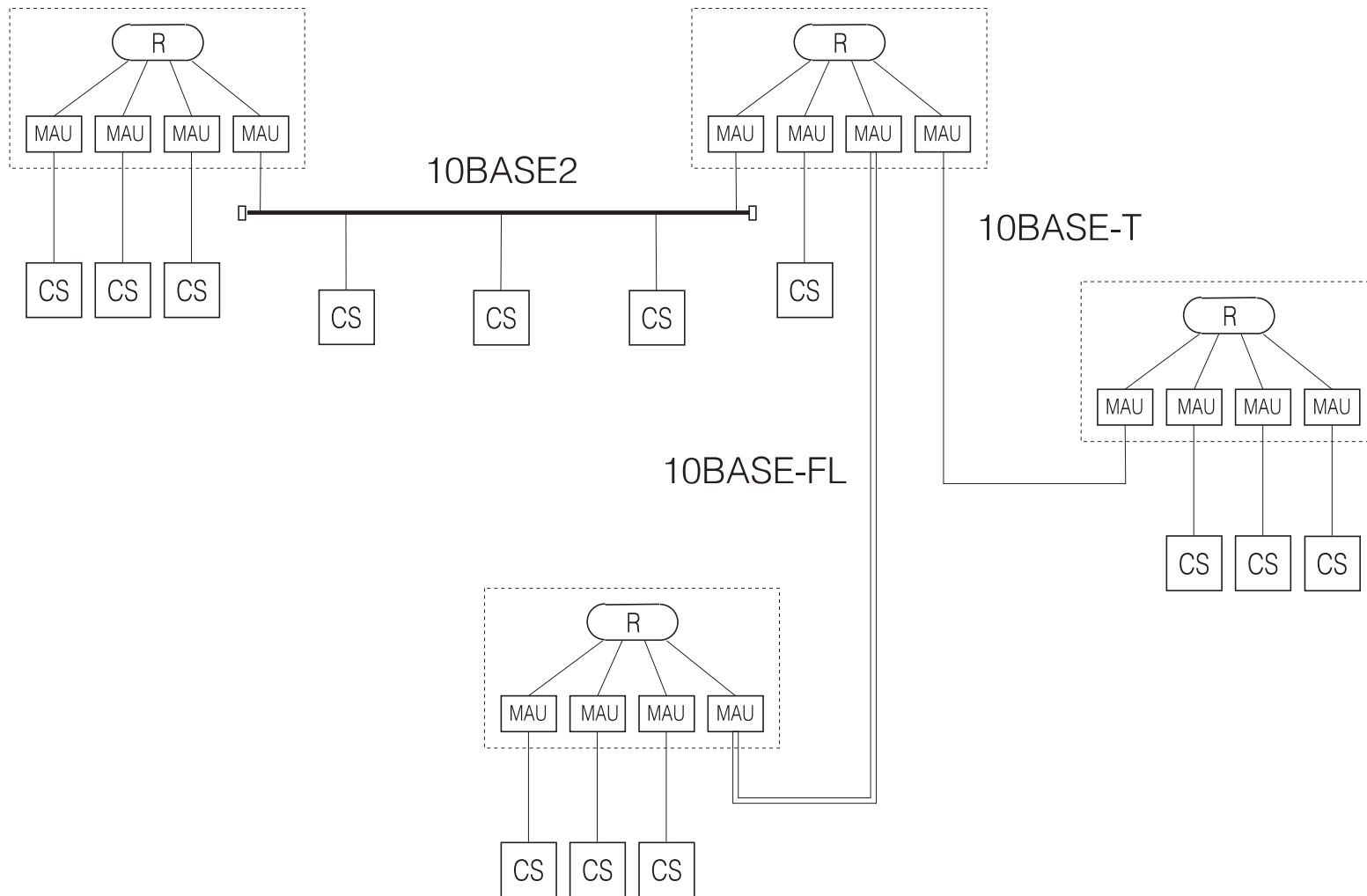

Synchronous Ethernet

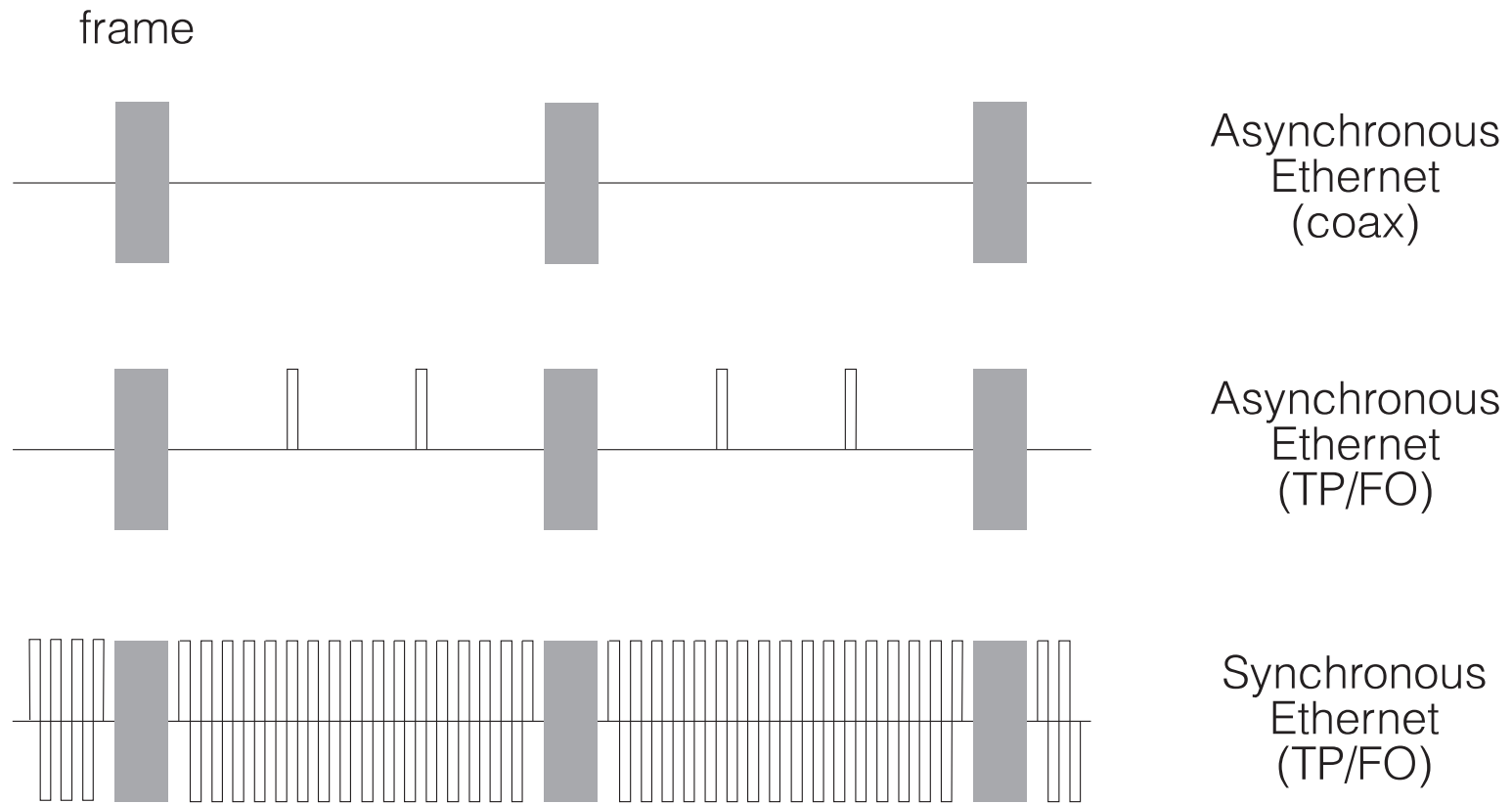

Ethernet bridging

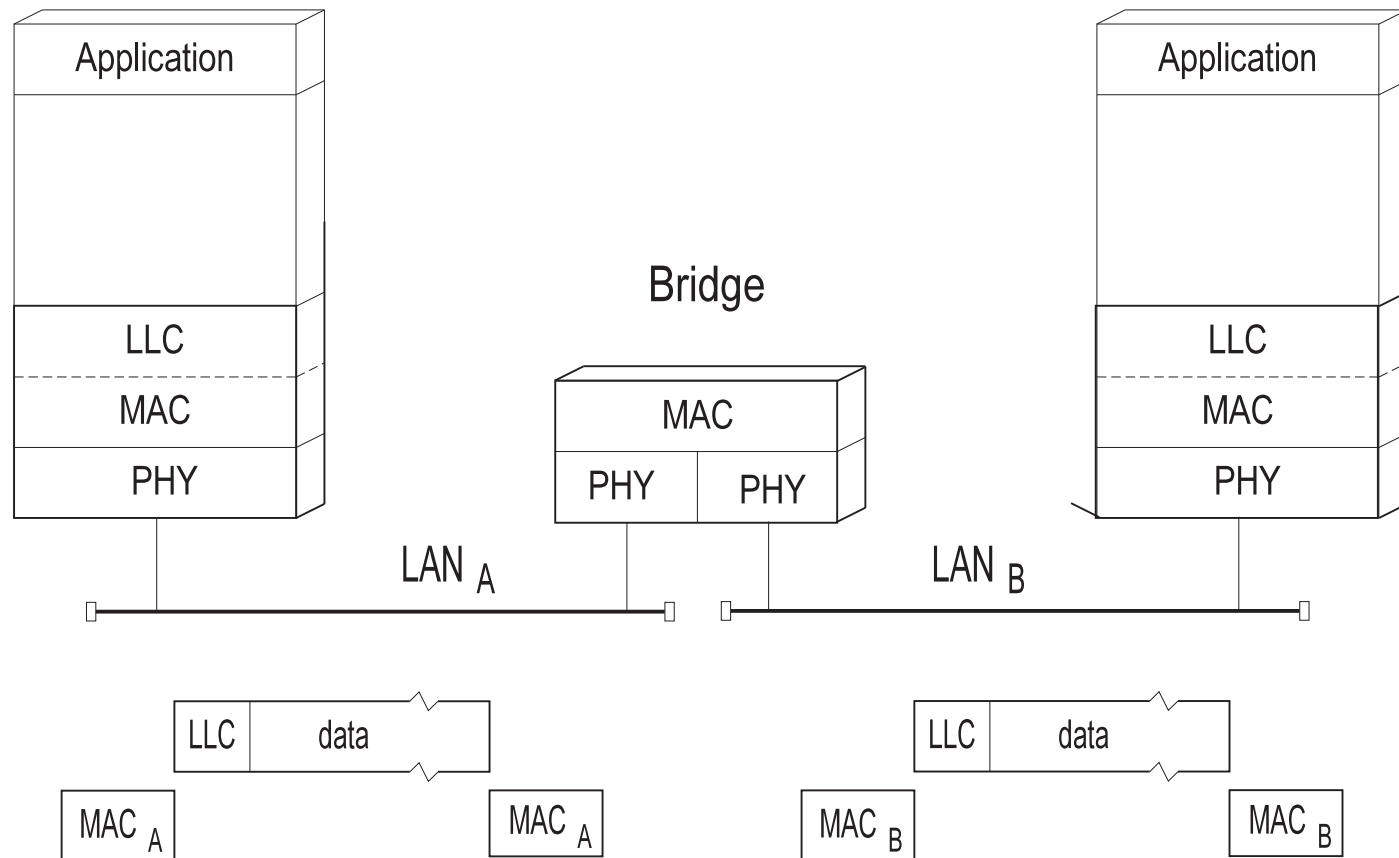

Ethernet bridging

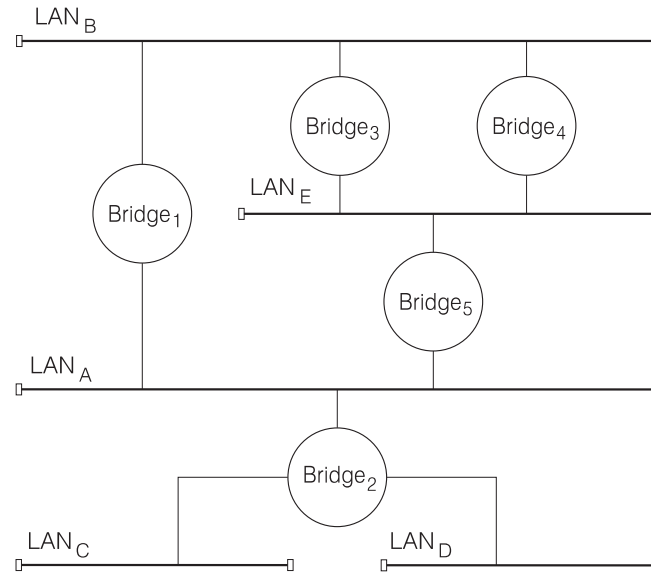

Bridge ₁		Bridge ₂			Bridge ₃		
	A	B	A	C	D	B	E
A	-	A	-	A	A	-	-
B	-	A	-	A	A	-	-
C	-	A	-	D	-	-	-
D	-	A	-	D	-	-	-
E	-	A	-	A	-	-	-

Bridge ₄		Bridge ₅		
	B	E	A	E
A	-	E	-	A
B	-	E	-	A
C	E	B	-	A
D	E	-	-	A
E	E	-	E	-

Learning and forwarding

Forwarding

Learning

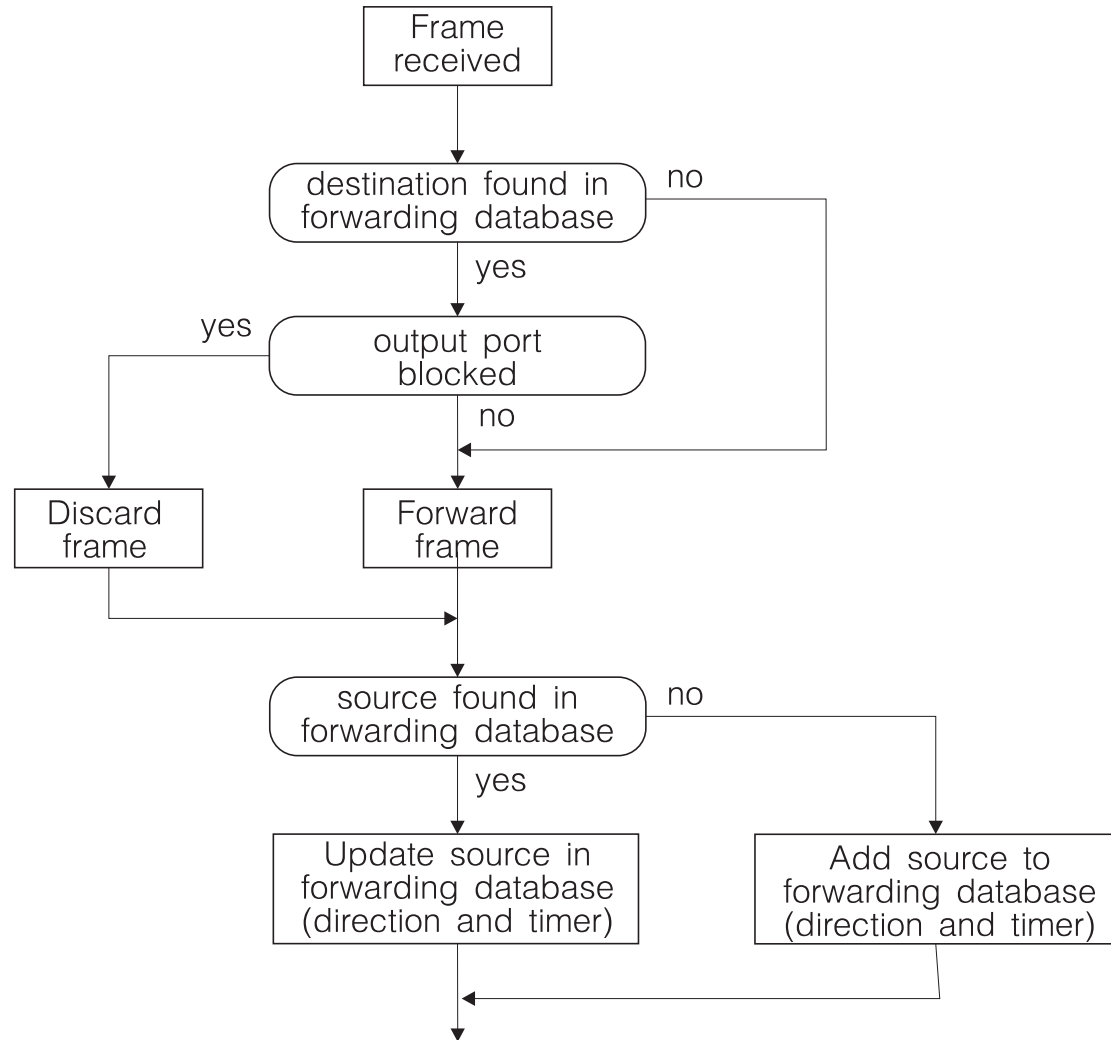

IEEE 802.1d Spanning tree

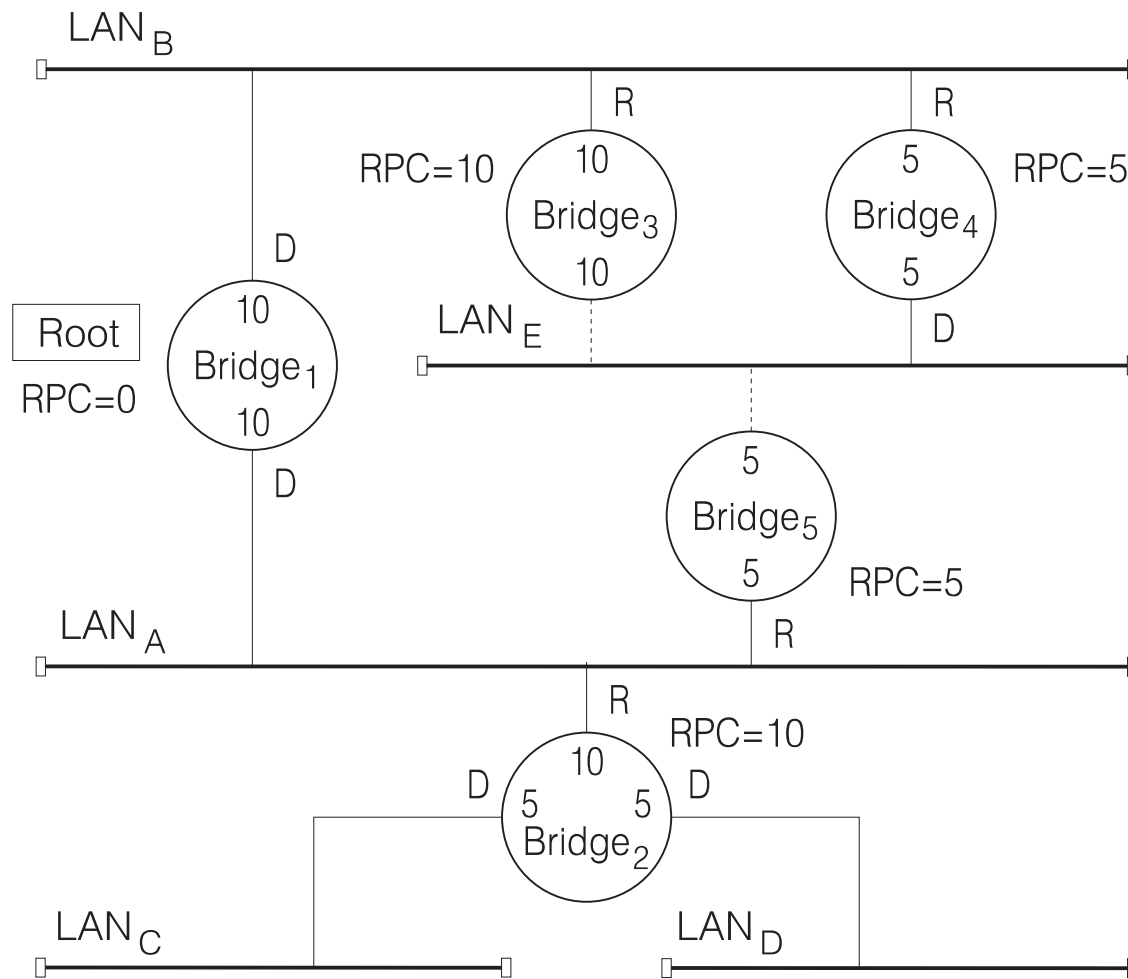

IEEE 802.1d Spanning tree

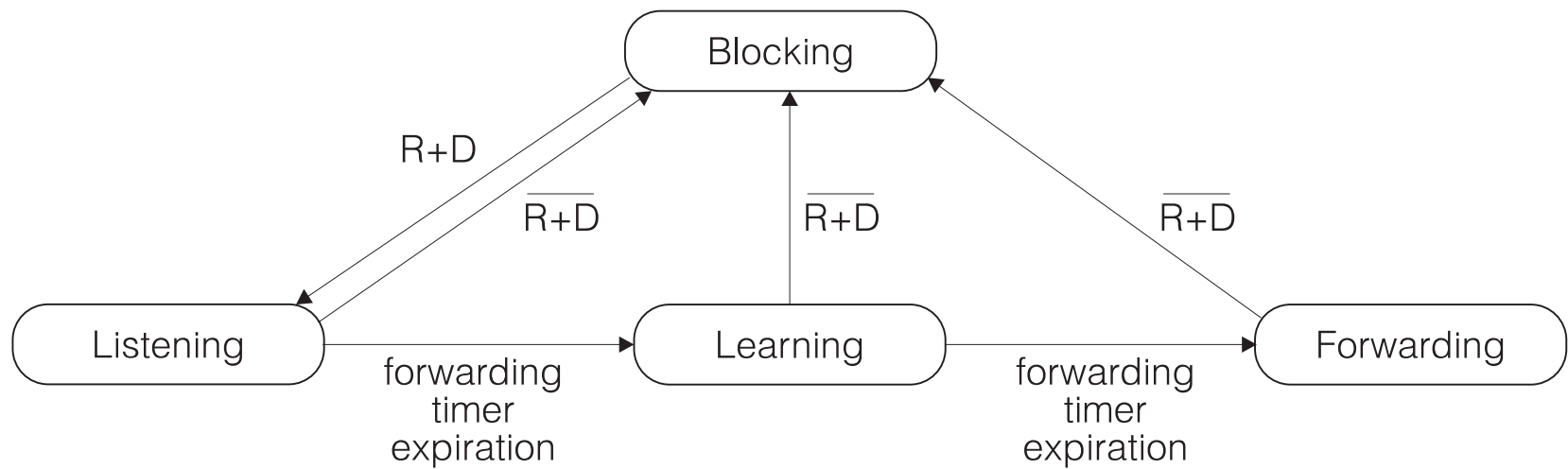

Remote & workgroup switches

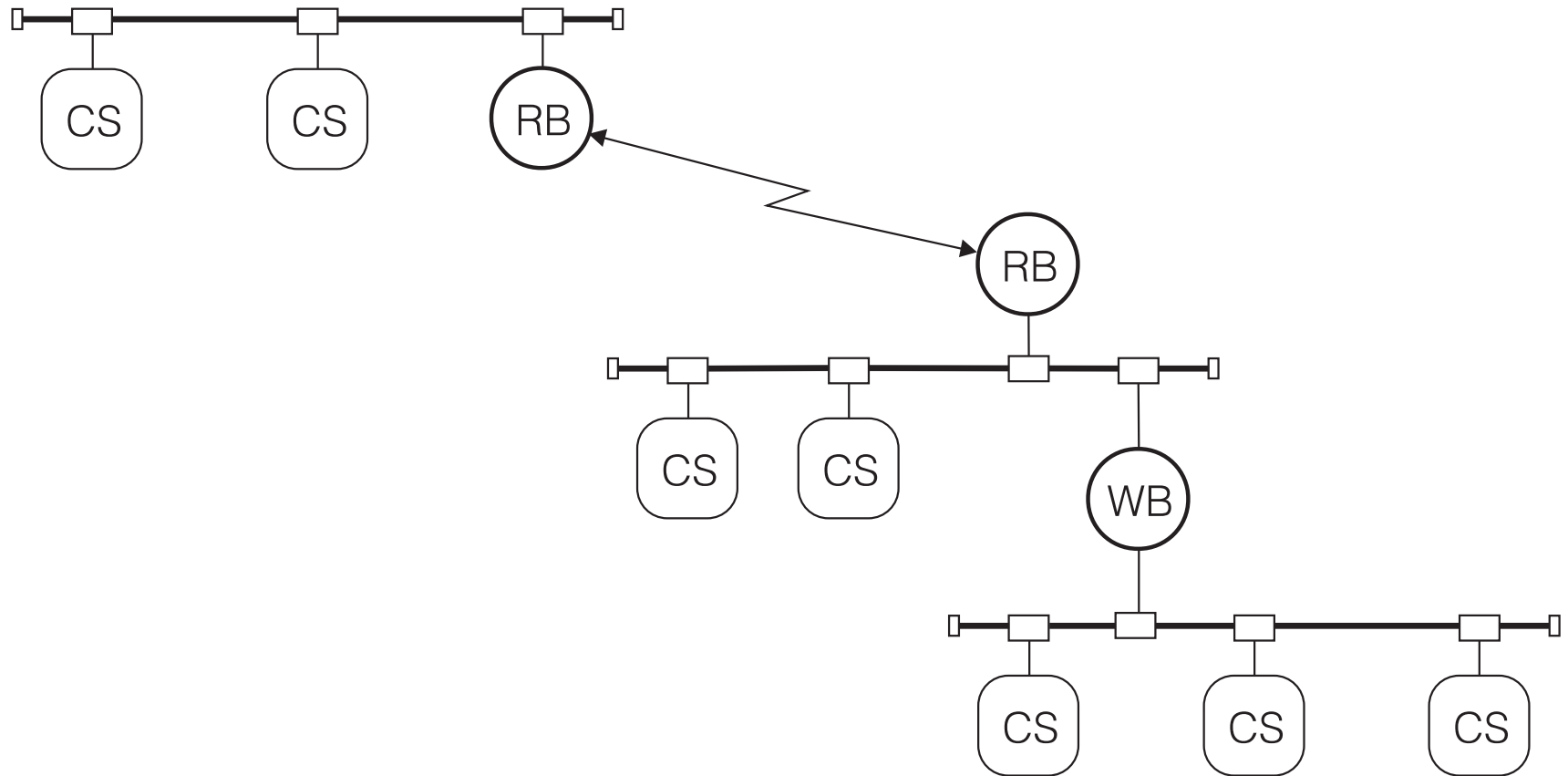

Ethernet switch

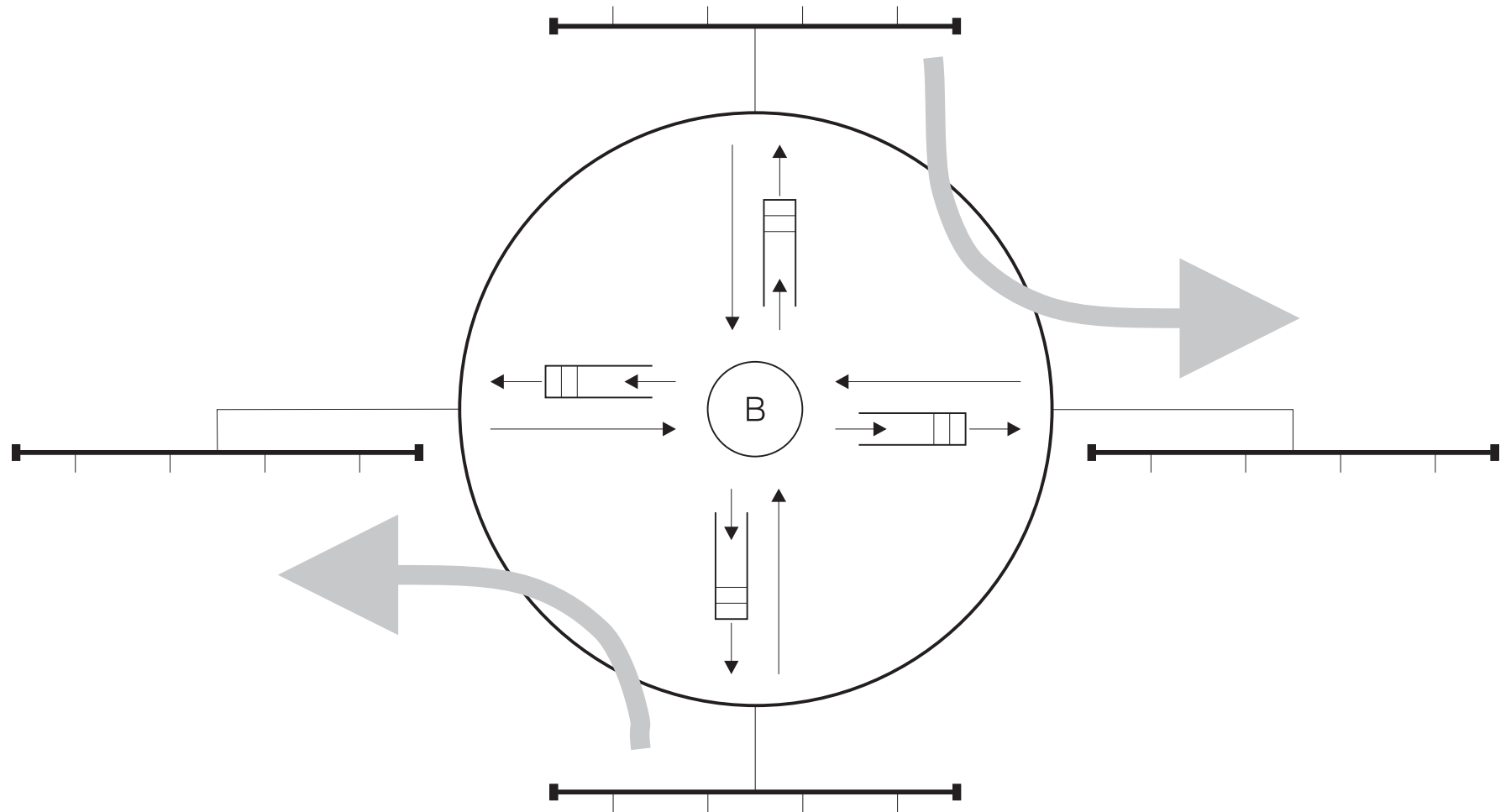

Switching modes

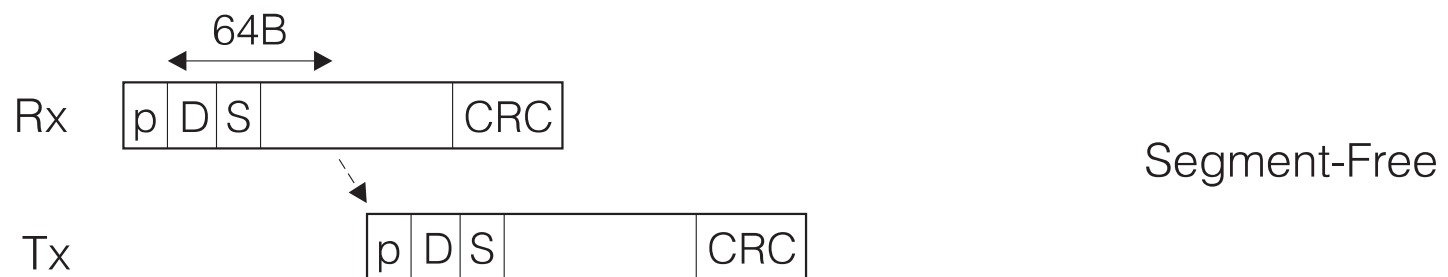
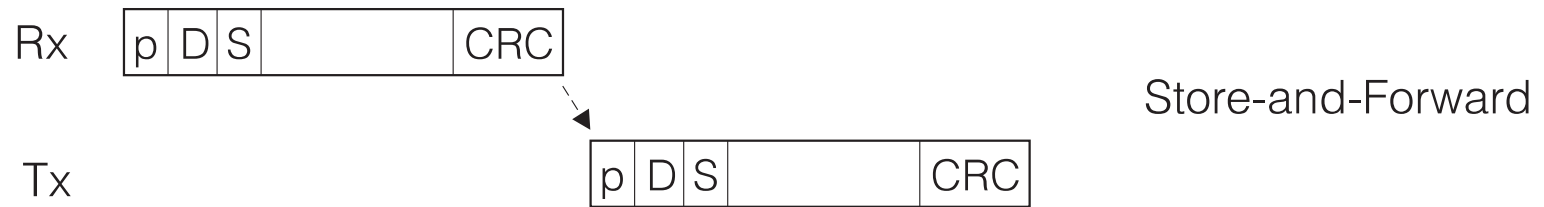

Source routing

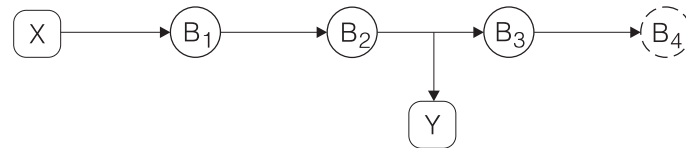
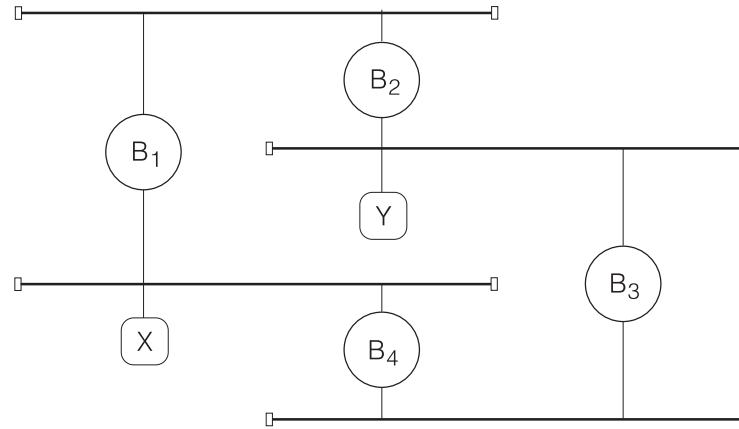

Single-Route
Broadcast
Request

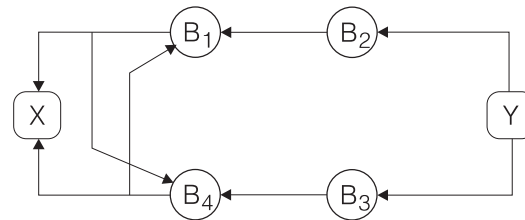

All-Routes
Broadcast
Response

Routing

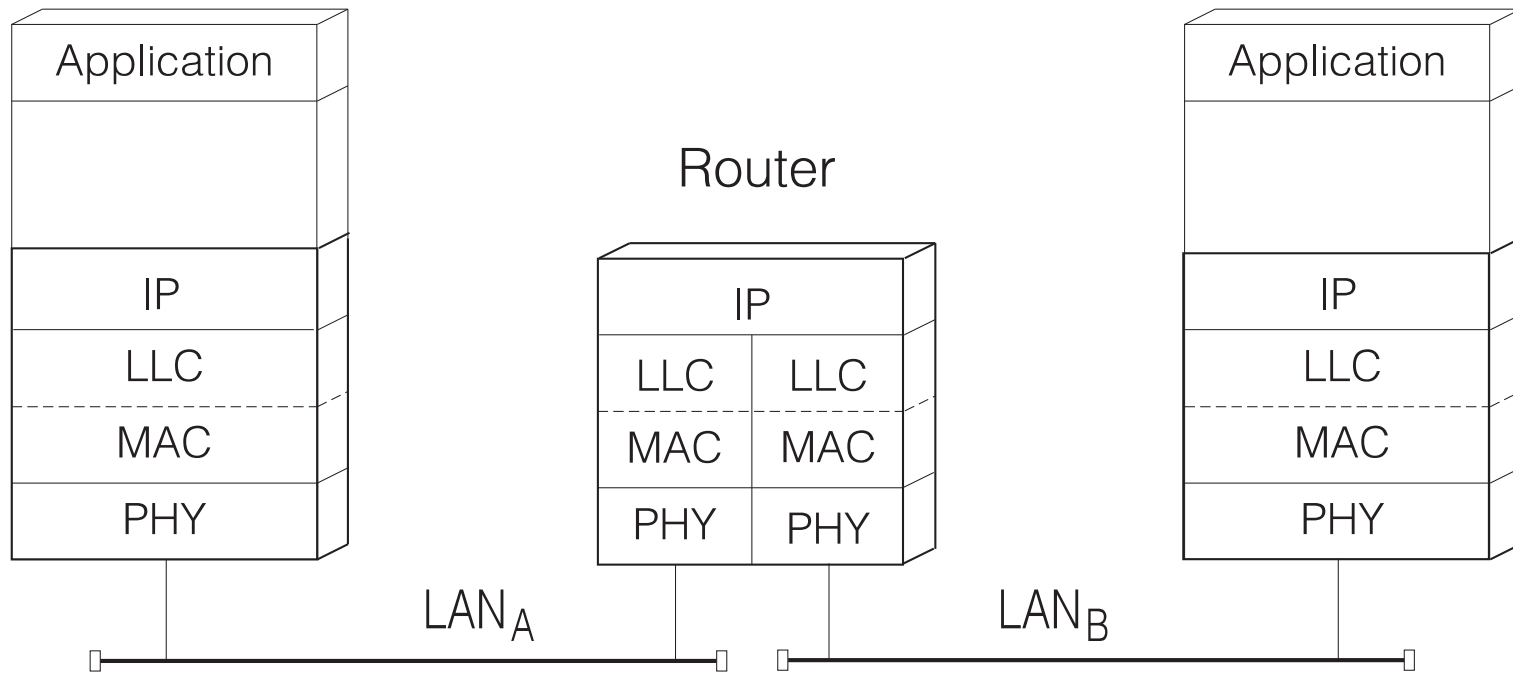

LAN connections

